

CDI

FLEXIBLE FURLER 2

INSTALLATION/OPERATING INSTRUCTIONS



277 Baker Avenue / PO Box 1250, Concord, MA 01742

Tel: 978-371-5508 Fax: 978-371-5597

Web: www.sailcdi.com

November 2001

WARNINGS

Improper installation of the Flexible Furler or improper reinstallation of the forestay can cause failure of the forestay, and could result in the loss of the mast and injury to crew members.

Before installation, check that toggles are used at both ends of the forestay. Improper toggling may cause the forestay to fatigue due to bending stresses.

After installation, check that all clevis pins and cotter pins removed during installation are replaced. Especially check that all turnbuckle pins are in place. Make sure the turnbuckle threads have full engagement. Check for free rotation of the unit, paying particular attention that the luff or the inside of the drum does not touch the turnbuckle body. If it touches, furling may unscrew the turnbuckle. Insure that the bearing is not jammed, as winching with a jammed bearing will transmit torsional loads to the turnbuckle which could lead to failure. Check to insure that at least 3" clearance exists to the side and above the halyard top fitting.

During operation, never winch the unit without checking for jams or snarls. Winching against an obstruction can sever or cause hidden damage to your forestay. Keep your unused halyards flipped to the after side of your spreaders. If the unit becomes hard to furl, investigate and correct the cause. Failure to do so can lead to the failure of the forestay.

The Flexible Furler is NOT designed to be used while your boat is in the water and passing under low clearance obstructions (bridges, power lines, etc) with mast is tipped forward and headstay attached to the bow. Lowering the mast in this manner is dangerous even without a furler, and can be further complicated by the weight of the furler and the sail.

INDEX

Warnings	Inside Front Cover
Specifications	1
Drawing	2
Parts List	3
Uncoiling and Straightening the Luff	4 - 5
Assembly	5 - 8
The Furling Line	9
Hoisting the Jib	10
Lowering the Jib	10
Sailing with Your Furler	11 - 12
Maintenance	12
Trailing Instructions	12
Sailmaker's/Rigger's Instructions	Inside Back Cover
Warranty	Back Cover

SPECIFICATIONS

Forestay Length	29 feet, maximum
Wire Size	1/8", 5/32", 3/16"
Forestay Fittings	There should be a toggle at both ends of the forestay (see second paragraph under Warnings above). The turnbuckle should be a 1/4" or 5/16" swage-on turnbuckle with T-bolt and toggle at bottom (see, page 5).
Mounting	System can not be mounted above turnbuckle. If you wish to raise system for better clearance, shorten stay and use linkplates below the turnbuckle.
Furling Line	5/32" or 3/16" dacron. If you prefer a larger diameter, you can de-core larger double braid line forward of the cockpit, thereby reducing the diameter as it winds on the drum.

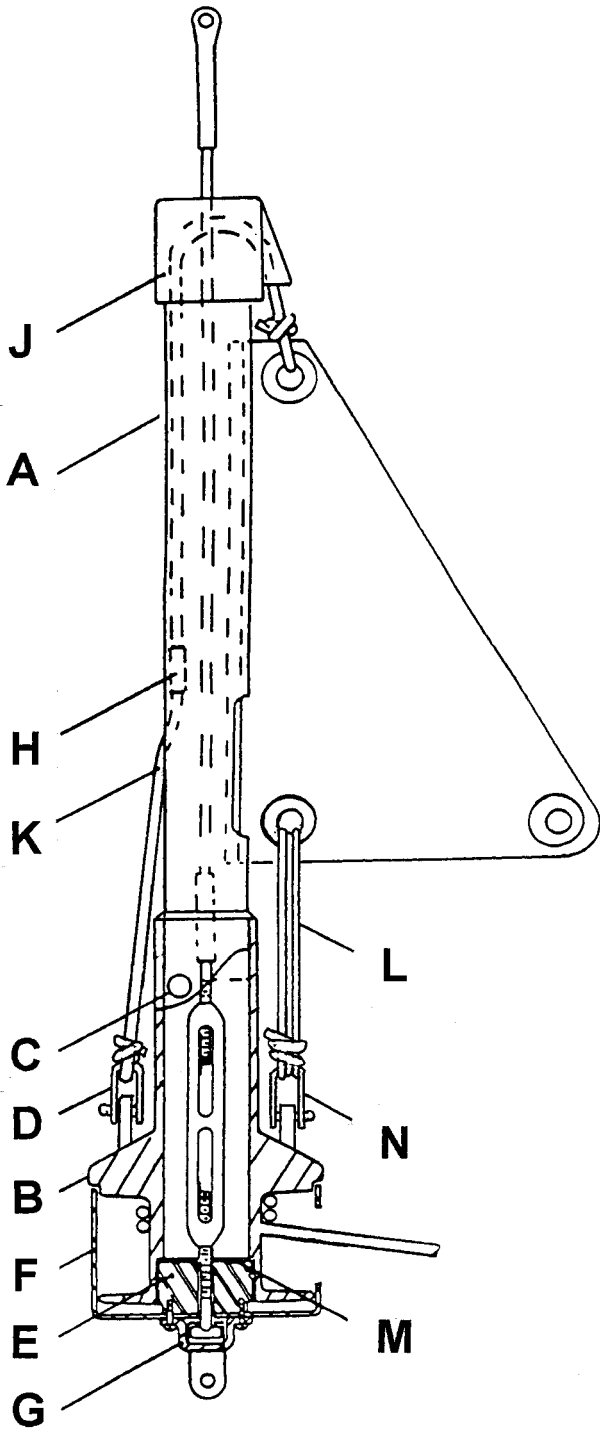

PARTS LIST

A	Luff	LFF2
B	Spool Assembly	2010
C	Luff Support Pin (3/16" x 1-1/2")	2009
D	Halyard Anchor Pin	1998
	Halyard Anchor Shackle	2007
E	Main Bearing	1033
F	Cup (Stainless Steel)	1807
G	Antirootation Strap	1081
H	Ferrule (part of halyard)	----
J	Halyard Top Fitting	2011
K	Halyard Assembly (1/4" x 33')	1932
L	Tack Tension Line (1/8" x 4')	2048
M	Thrust Washer	1253
N	Tack Tension Pin	1998
	Tack Tension Shackle	2007
<i>Not Shown</i>	Instruction Manual	1049

UNCOILING AND STRAIGHTENING THE LUFF – PLEASE READ CAREFULLY!

If you received the luff coiled, *BE CAREFUL* while cutting the tape that holds the luff coiled. *THE LUFF CAN UNCOIL WITH CONSIDERABLE FORCE AND CAUSE INJURY.*

Start removing the tape by cutting the band retaining the outside end of the coil while holding the straight portion. Gently uncoil to the next band of tape. Repeat this process until all tape has been removed. When cutting the last piece of tape, the coil will have a tendency to spring outwards so be cautious. Never cut the tape restraining the inner end first as the coil will spring open when the last tape is cut.

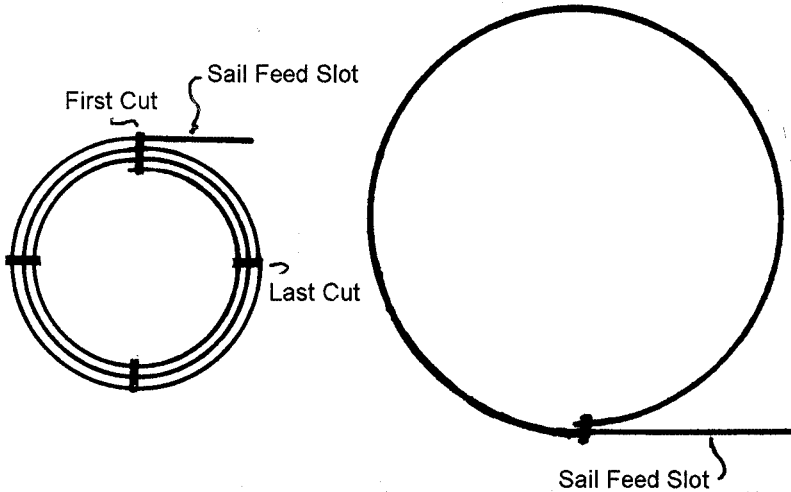

When the tape is removed, the luff will still be curved. To straighten, you will need three people. NEVER try to straighten by laying luff on the ground and weighting it down along its length. IT WILL TAKE A YEAR! Rather, with one person at each end and the others spaced along the luff, recoil the curved portion in one large loop in the opposite direction. Note that the lower end from the sail feed slot to the bottom was shipped straight and should not be recoiled (see drawing above left).

After coiling in the opposite direction, tape the upper end to the lower portion above the sail feed slot (see drawing previous page, right) leaving the straight portion free. Leave the coil re-coiled for several hours, a minimum of three if it's warm, longer if it's cold. After this time, carefully cut the tape and check the straightness. The luff does not need to be perfectly straight as a tight forestay will finish the job.

Clean the luff with a rag soaked in paint thinner. For deep scratches and ground in dirt, rub with a rag soaked in acetone. Be cautious, however, as prolonged exposure to acetone will destroy the luff.

ASSEMBLY

Assembly is easiest with the mast down although it can be done with the mast up (see instructions below).

Assembly of Luff Extrusion, Halyard Top Fitting and Halyard

1. Measure the pin to pin length (L below) of the forestay with the turnbuckle in its normal state of adjustment. If the mast is up, you will have to raise a tape on the jib halyard and add an amount approximately equal to the distance from the top end of the tape to the pin at the top of the forestay. Cut off the top end of the luff so that the total luff length is $12 \frac{1}{4}$ " less than the measured pin to pin length.

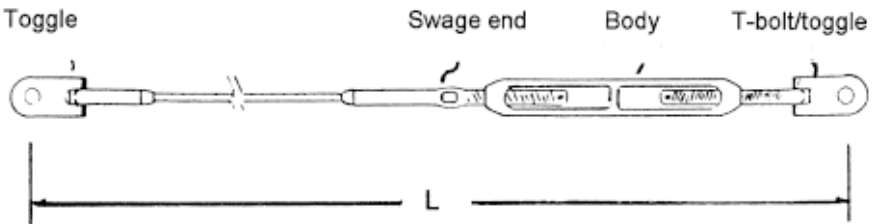

2. The Flexible Furler uses a built-in 1/4" rope halyard instead of your boats halyard. One end of the halyard has had the rope core removed leaving only the outer braid while the other end has both core and braid intact. The de-cored end is closest to the metal ferrule. To install, insert the intact end into the cavity in the halyard top fitting and through the off-center curved hole until the halyard exits from the "nose" on the halyard top fitting. Pull the halyard through until the ferrule is about a foot from the halyard top fitting.

3. Pass the decored section of the line through the top of the groove in the luff extrusion opposite the groove with the sail feed slot (see photos below). Push the ferrule an inch down into groove. You should now be able to pull on the decored section of the halyard and have the ferrule slide inside the groove. Don't do this until you're ready to raise the sail. Fit the halyard top fitting over the top of the luff with the halyard exiting the side of the halyard top fitting over the groove with the sail feed slot. Tighten locking screw. Tie a messenger line, the length of the luff, to the decored end of the halyard. This line will be used to raise the sail.



4. Completely unscrew the swage-end of the turnbuckle and T-bolt and toggle from the turn buckle body (see page 5 for terminology).

5. Pass the swage-end and wire down through the halyard top fitting/luff extrusion assembly. If the mast is stepped, first pass a light line through the center hole of halyard top fitting/luff assembly for the full length of the luff. Make the upper end of that line fast to the cotter pin hole in the swage-end of the turnbuckle using a piece of wire to make the link. Pull on the light line while pushing the luff up the forestay. When the swage-end and wire appear, screw on the turnbuckle body to prevent the luff from sliding down.

Assembling the Cup, Bearing and Antirotation Strap

6. If your forestay turnbuckle screw is 5/16" in diameter, drill out the center hole of the bearing with a 21/64" drill.
7. Place the antirotation strap between the two sides of the toggle. Add enough 5/16" spacer washers on the T-bolt so when the antirotation strap is up against the bottom of the T-bolt or cross bar, the washers are just under the top of the antirotation strap (see photo at left below). Push the T-bolt through the center hole in the cup and the bearing (see photo at right below). Screw in the two pan head screws through the antirotation strap, cup and into the bearing. Refer to page 9, 'Bringing the Furling Line Aft' to select the correct pair of holes.



T-bolt/toggle with spacer washers and antirotation strap in place



Assembling cup, bearing and antirotation strap

8. Slide the spool over the turnbuckle body and luff. Insure thrust washer (part M, a 1 3/4" flat stainless washer) is in place inside the bearing cavity. Screw the T-bolt into the turnbuckle body until the overall forestay length is correct. Replace both cotter pins. Note: final adjustment of the turnbuckle can be done after the installation is complete (see below).

Final Assembly

9. Step the mast (if unstepped), attach the forestay to the chainplate. Tension rig using backstay turnbuckle or upper shrouds (if there is no backstay).

10. Slide the spool body down the luff, into the cup and over the main bearing, insuring thrust washer is in place. Lift the luff up off the turnbuckle body, insert the luff support pin through the hole in the spool throat. The luff rests on top of this pin. *CAUTION:* the luff must not sit on the turnbuckle body as turning the furler might unscrew the turnbuckle causing dismasting.

11. Pass the furling line through the opening in the side of the cup, then up through the hole in the top of the spool flange. Tie an overhand knot to prevent it from escaping. Before raising jib, rotate the furler so there are about 20 turns of furling line on the spool. This will be finished off later.

12. If your jib is full or almost full hoist (dimension A in drawing at right is less than 12" when sail is in desired position), pull the halyard ferrule hard up against the halyard top fitting and cut the halyard so that when it is tied to the sail, the head of the sail is just below the sail feed slot. Melt end of rope to prevent fraying.

If dimension A is more than 12" when jib is hoisted to desired position, pull the halyard ferrule up against the halyard top fitting and tie the halyard to the sail so the head of the sail is below the sail feed slot by an amount approximately equal to dimension A. When the sail is raised, there must enough decoed halyard to reach and be made fast to the halyard anchor shackle. This may take some experimentation so cut the halyard only after you confirm the length.

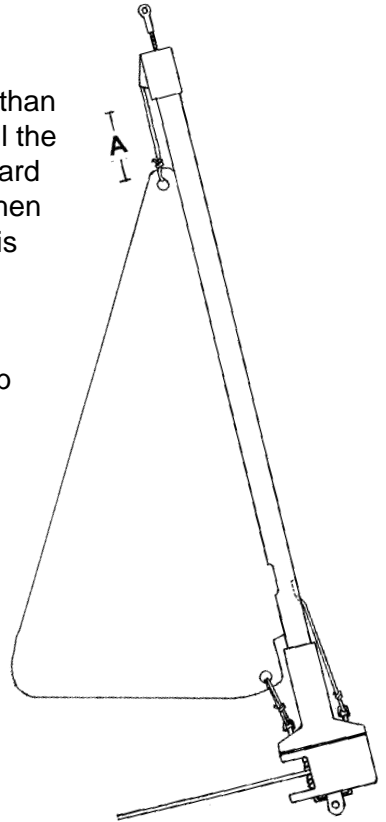

13. If the forestay length needs to be adjusted, remove the luff support pin, slide the spool to expose turnbuckle and make your adjustment. In so doing, you may knock out the thrust washer. After adjusting the turnbuckle, be sure thrust washer is in place.

THE FURLING LINE (*Please read carefully*)

1. Position the first fairlead so the furling line exits the cup at right angles to the forestay and approximately in the middle of the cup athwartships. Failure to properly position this first lead will result in chafing of the furling line. In most cases, the first fairlead must be mounted on the deck. Properly bed the screws.



Locating the first fairlead

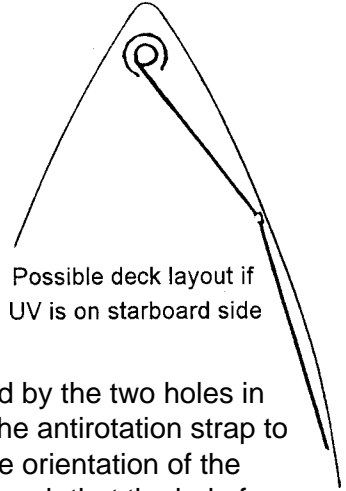

Possible deck layout if
UV is on starboard side

2. The orientation of the cup is determined by the two holes in the bottom of the cup you select to mount the antirotation strap to the cup and bearing (see 5, page 7) and the orientation of the chainplate. Most often, the cup is mounted such that the hole for the furling line is facing aft. If you wish to position the first lead at or near the rail, you may have to turn the cup 45 degrees to the centerline. This may be done by selecting holes on the diagonal when installing the antirotation strap.

3. Continue the furling line aft toward the cockpit using as many or as few leads as you wish. Try to avoid large angle changes with the furling line as such angle changes rapidly increase the force required to furl the sail even when using low friction blocks.

4. Place a cleat near the cockpit away from other sail handling equipment. When the sail is furled, there's a lot of line to stow.

5. The system is designed for 3/16" dacron line. Make sure you have enough to completely furl your largest sail plus about five turns. This will allow you to furl an extra tight furl in heavy winds and still have a couple of turns left. Before hoisting sail for the first time, wind about 20 turns on the spool.

HOISTING THE JIB

1. Attach the halyard to the jib.

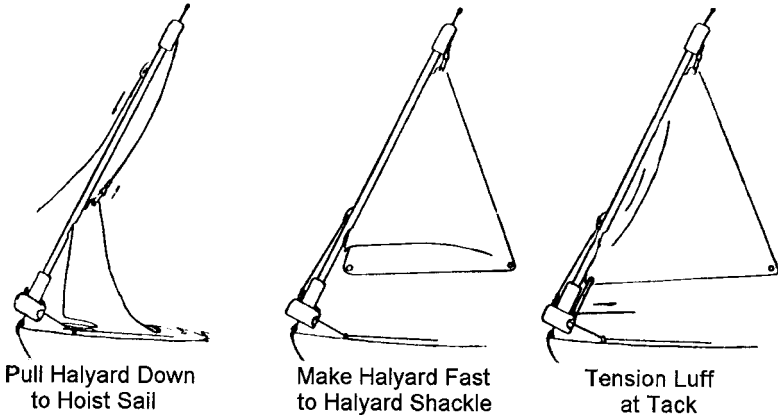

2. Pull up the sail by pulling down the decored end of the halyard using the messenger line attached to the decored end (see #3, page 6), while feeding the sail into the sail feed slot. If raising and lowering the sail frequently, a pre-feeder should be added.
3. When the sail is fully hoisted, untie the messenger line. Pass the decored end of the halyard through the halyard shackle on top of spool and finish off with bowline or some half hitches. After taping rope to prevent fraying, cut off the unused decored end. Melt end and remove tape.
4. Tension the luff of the sail with the 1/8" tack tension line, passing two or three parts through the downhaul shackle on spool flange and grommet on sail, and finish off with some half hitches.
5. Add or eliminate furling line on drum as necessary. When sail is furled tightly, there should be two or three turns left on the spool.

LOWERING THE JIB

1. Ease off the tack tension line.
2. Cast off the halyard from the halyard shackle. Attach a messenger line to the decored end of the halyard and lower the jib.

SAILING WITH YOUR FURLER

The Flexible Furler is a set-it-and-forget-it furling and reefing system. It requires no maintenance although keeping the bearing clean is a good idea. The jib requires only enough tension to remove the wrinkles along the luff of the sail. This tension will be quite low (less than 50 pounds) because modern sails are quite stiff requiring little stretching and because the luff tape will prevent scalloping often encountered with hank-on sails. This allows the sail to be set up for the entire season without need for adjustment before and after each use.

Controlling draft by varying the luff tension is effective only with the sail fully deployed. If you are sailing to windward frequently in heavy weather and reef frequently, it may be appropriate to have a foam tape installed which will help remove the belly in a reefed sail. We suggest you consult your sailmaker.

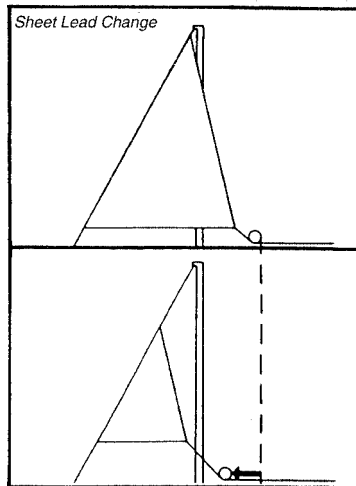

When sailing reefed, you must move the jib leads forward to maintain the proper sheet angle. Failure to do so will give poor sail shape and could cause the furler to rise off the bearing.

To furl or reef ease the sheet and pull the furling line until you reach the amount of sail you wish left deployed. Cleat down the furling line. Note: letting the sheet run free while furling may make furling a little easier but will result in an uneven furl.

To unfurl or unreef, ease the furling line while trimming the sheet. Always keep some tension on the furling line to insure a smooth wrapping of the furling line on the drum.

In certain conditions, you may wish to use a winch to get the furling started. Be careful that there is no extraneous ship's halyard wrapping in the furler while you winch as this could eventually jam the furler and/or damage the headstay. Always look up at the top of the furler while winching, stop and clear anything that snarls. Furling should not get any more difficult as the sail is brought in. It should get easier. If it gets harder, stop and determine why.

Always keep unused halyards flipped aft of the spreaders. Do not clip them to the bow.

MAINTENANCE

No routine maintenance is required, but an occasional rinsing with fresh water is a good idea. We do not recommend the use of wet lubricants (grease) as such lubricants can hold wear causing particles in suspension. Dry lubricants (teflon sprays, etc.) are fine to make furling easier. A ball bearing is also available for the ultimate in easy furling and reefing.

When storing for prolonged periods, it is best to strap the furler along the mast, supporting the furler to avoid any potential sagging at the ends as well as in the middle. If coiling for short periods, do not coil in a radius of less than 3 feet (6 foot diameter).

Do not expose the furler to temperatures in excess of 140 degrees

F. Such temperatures may frequently occur in warm climates under a boat cover and void the warranty.

TRAILERING WITH YOUR FLEXIBLE FURLER

When trailering, the Furler should be lashed along the mast, keeping it as straight as possible. The ends must be supported to keep the luff from bouncing while driving which could lead to the fatigue failure of the luff.

SAILMAKER'S INSTRUCTIONS

Luff tape required is #6. Sail luff deduction is 13" from pin-to-pin length.

We recommend use of webbing at the head and tack instead of metal grommets. This allows the sail to reef and furl more evenly.

The Flexible Furler can not be mounted above the turnbuckle as this potentially puts excessive torsional stress on the turnbuckle. This, in turn, could lead to the unscrewing of the turnbuckle and dismasting. To raise the system, shorten the headstay the desired amount and install linkplates under the turnbuckle.

The FF2 can only be used with 1/4" and 5/16" turnbuckles. Turnbuckle must have threaded swage stud and T-bolt and toggle. Stays with other fittings at the bottom (eyes, jaws, etc.) must be altered as the antirotation strap will not fit using these other fittings. We recommend replacing closed body, lock nut turnbuckles with open body, cotter pinned turnbuckles. Lock nuts are not a satisfactory way to lock turnbuckles. Any improper installation could lead to an unscrewing torque on the turnbuckle that could lead, in turn, to the loss of the mast.

Toggles are recommended at the top of the forestay as well as the bottom.

LIMITED 7 YEAR WARRANTY

The Flexible Furler is warranted to remain functional for 7 years from date of purchase. You must be the original purchaser of the unit. If, during this period, any part becomes non-functional, CDI will repair or replace it, free of charge, except for freight.

This warranty covers:

At Sea: winching against obstructions, unseamanlike use, and dismastings.

In Boatyards: rough and abusive handling. The luff is warranted even if run over by light vehicles, excluding 3/4 ton pick-up trucks, marine railways and travelifts.

The warranty does not cover:

At Sea: Shipwreck, collision and acts of God. The warranty is void if the mast is not fixed in place vertically at all times while the boat is in the water. Tipping the mast forward to pass under bridges, power lines or other low clearance instructions voids the warranty.

On Trailers: Collision; being dragged on the ground; improper stowage resulting in kinks, bends and twists; thrumming in the wind; and damage due to the luff not being supported over its entire length. (See trailering instructions.)

Boatyards and/or Storage: Kinks, twists and bends due to improper storage (see maintenance instructions).

This warranty remains in force for charter and other commercial operations. No maintenance is required to keep the warranty in force.